

6 ELECTRICAL SYSTEM

MECHANISM

CONTENTS

1. WIRING DIAGRAM	6-M1
2. STARTING SYSTEM	6-M4
[1] SAFETY SWITCH.....	6-M4
3. LIGHTING SYSTEM	6-M5
[1] HEAD LIGHT.....	6-M5
[2] TURN SIGNAL LIGHT	6-M5
[3] HAZARD LIGHT.....	6-M6
[4] EASY CHECKER.....	6-M6

1. WIRING DIAGRAM

Color of Wiring

W White	WR White / Red	BW Black / White
R Red	WY White / Yellow	BR Black / Red
L Blue	RB Red / Black	GW Green / White
P Pink	RW Red / White	YR Yellow / Red
B Black	RG Red / Green	YL Yellow / Blue
Br Brown	RY Red / Yellow	LW Blue / White
Sb Sky Blue		

W1019456

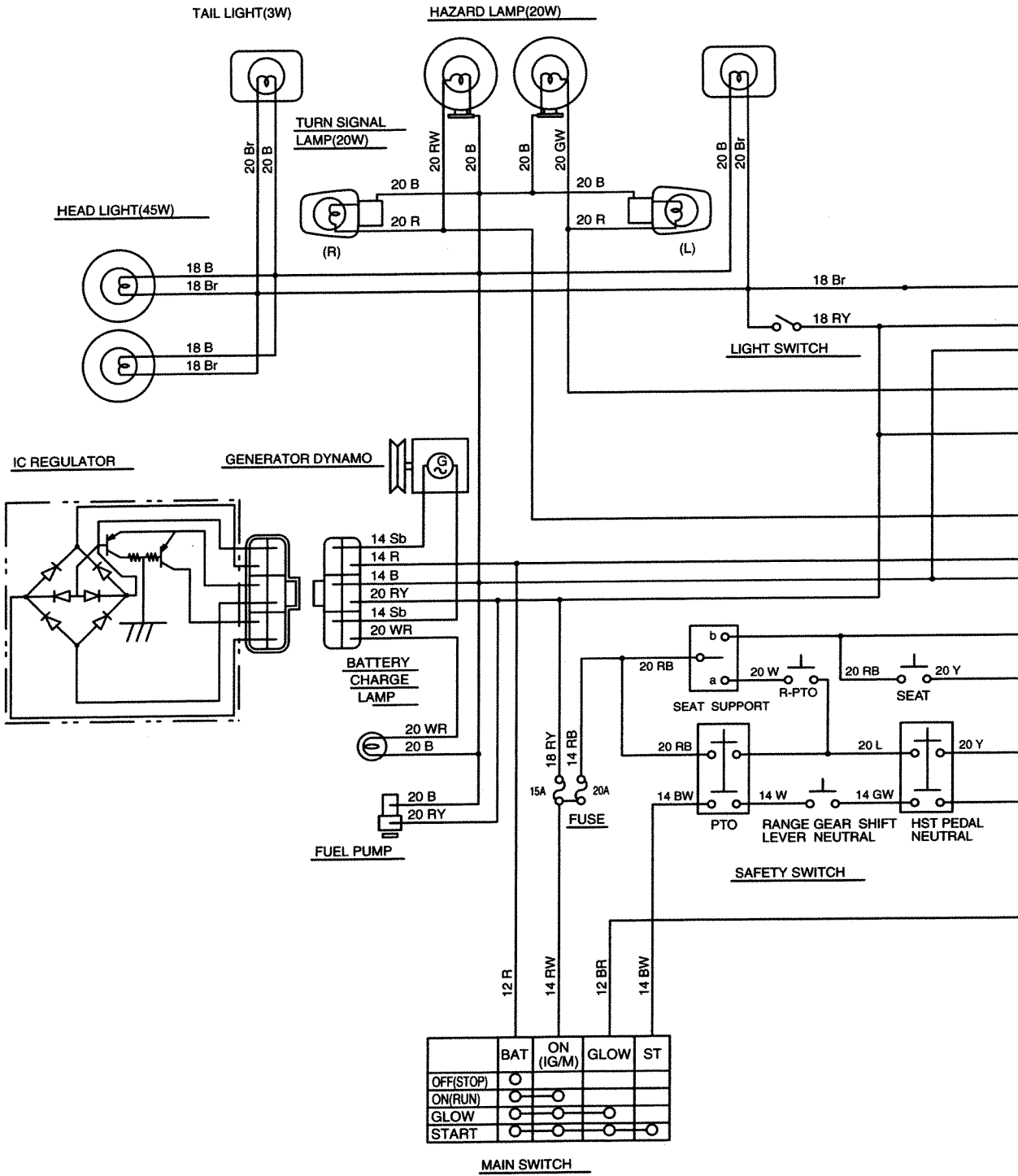

3TVAAAD9P011A

2. STARTING SYSTEM

[1] SAFETY SWITCH

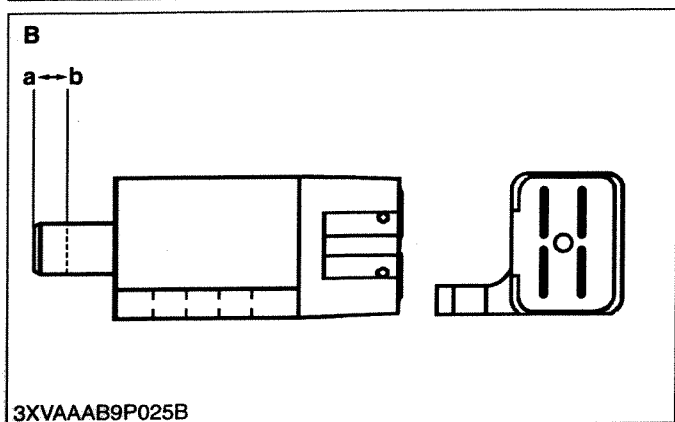
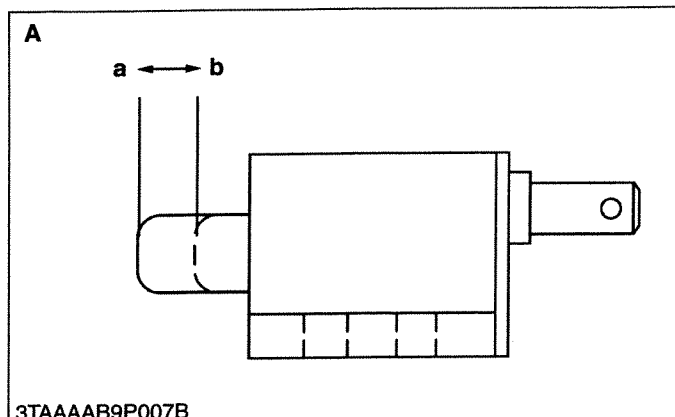

The safety switch prevents current from flowing to the starter when the safety switches are not depressed. This is to ensure safe starting.

The safety switches of single pole (A) are located two (range gear shift lever and PTO select lever) different position.

The safety switches of double pole (B) are located two (HST trunnion and PTO clutch lever) different position.

- | | |
|---|----------------|
| A : Safety Switch of Single Pole | a : OFF |
| | b : ON |
| B : Safety Switch of Double Pole | |
| | |

W1013107

3. LIGHTING SYSTEM

[1] HEAD LIGHT

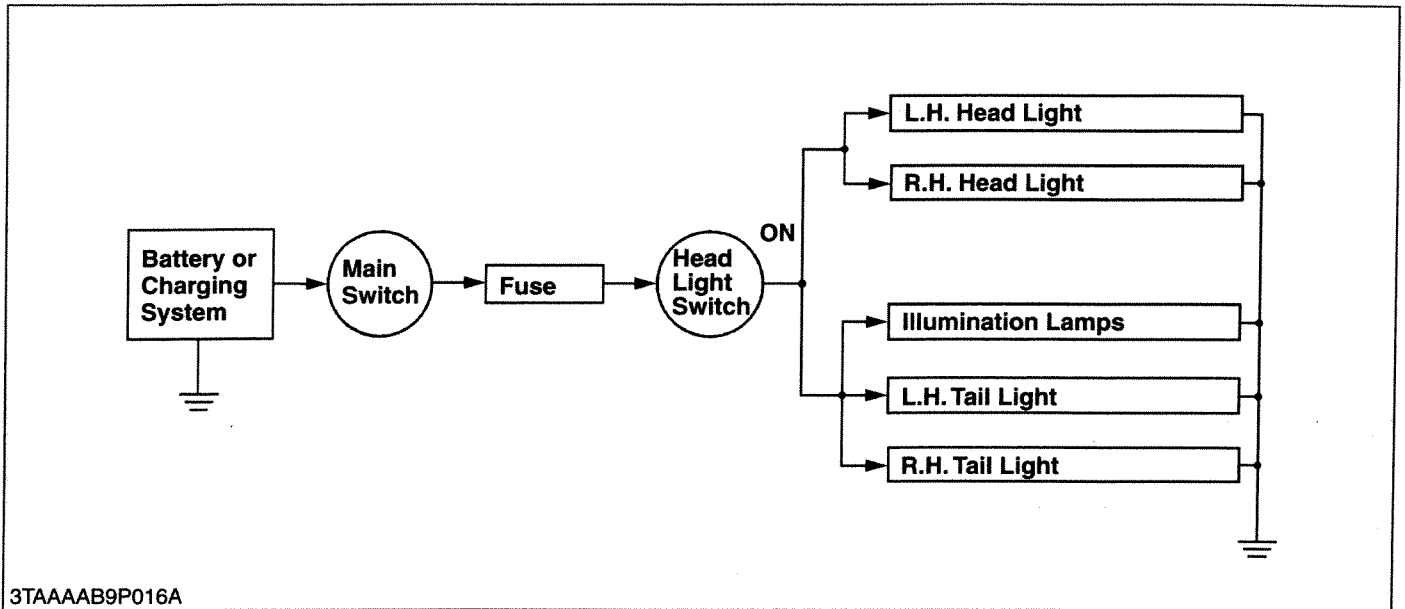

The head light switch has two positions; **OFF** and **ON**.
 Current passes through the light circuit as shown in the figure above.

[2] TURN SIGNAL LIGHT

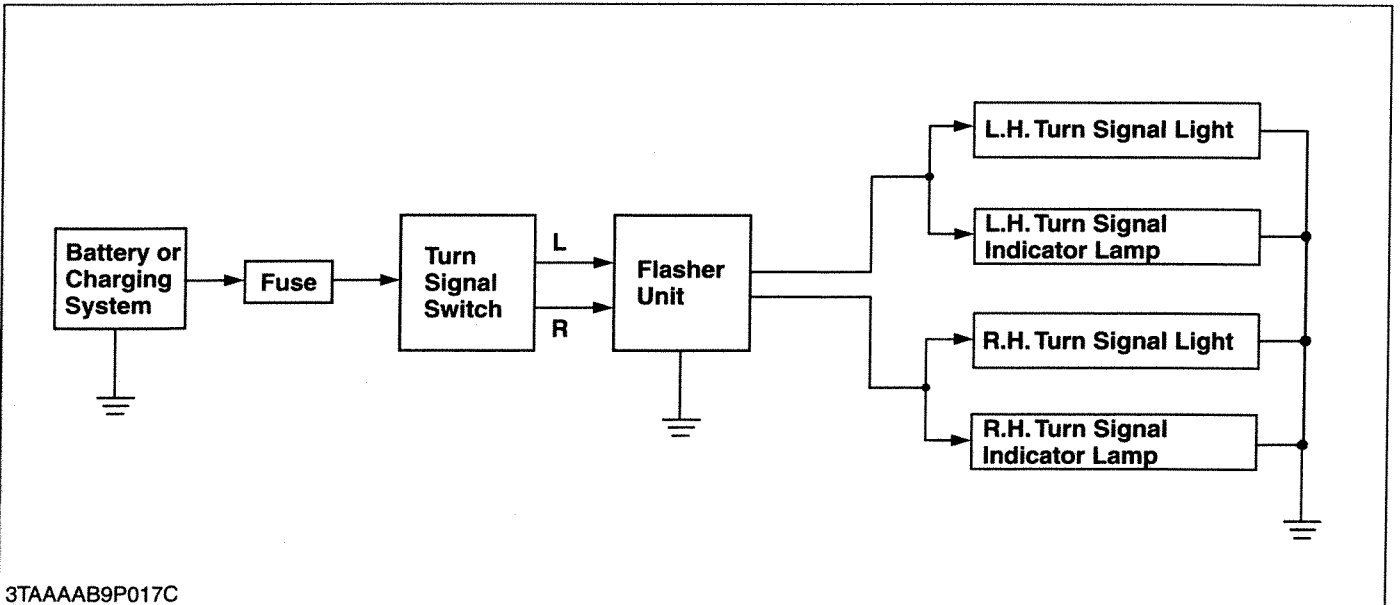

The turn signal switch has three positions; **OFF**, **L** and **R**. When using turn signal switch, turn signal only one side light and other one stays on.

[3] HAZARD LIGHT

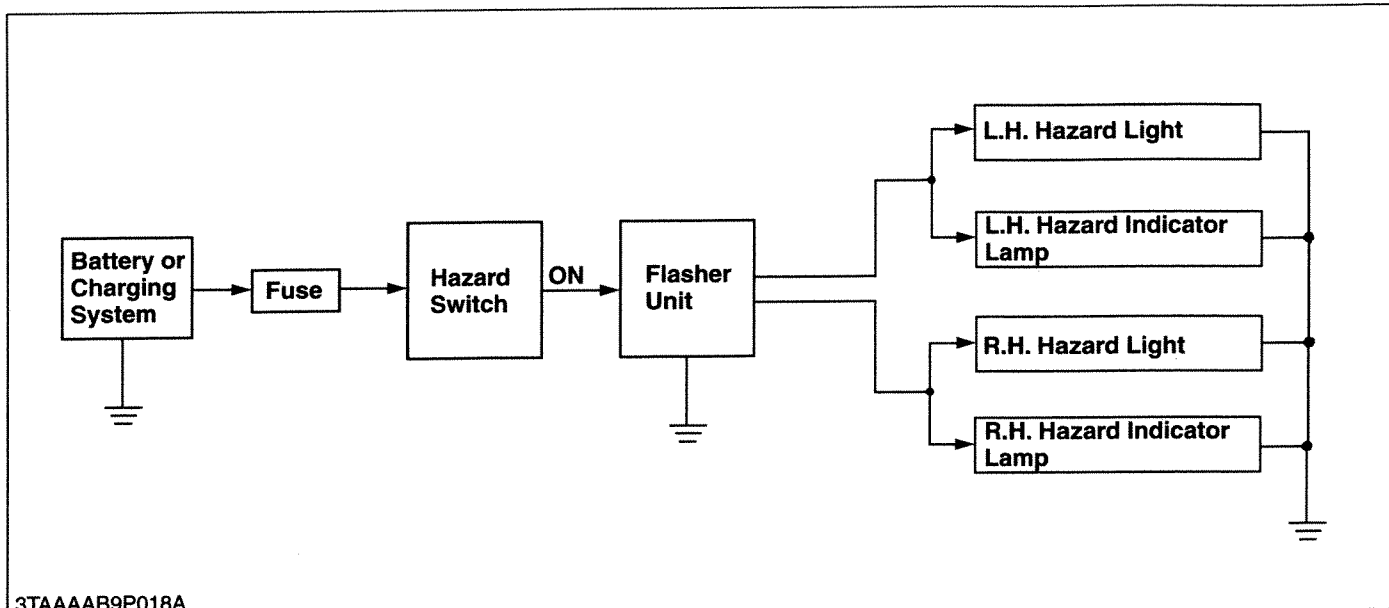

Hazard switch has two positions; **ON** and **OFF**. Blinking the hazard lights and indicator lamps as shown in the figure above.

[4] EASY CHECKER

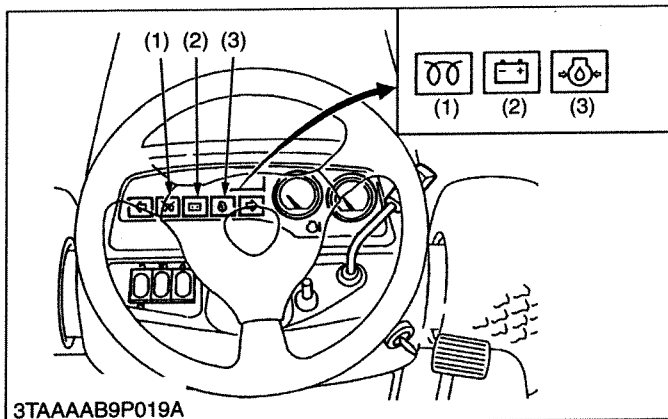

■ Indication Items

(1) Pre-heat Indicator Lamp

When the key switch is in the “Pre-heat” position, the pre-heat indicator lamp illuminates.

(2) Charge Lamp

When the charging system is not functioning properly, this lamp illuminates.

(3) Oil Pressure Lamp

When the engine oil pressure is low, this lamp illuminates.

W1013386

SERVICING

CONTENTS

1. TROUBLESHOOTING	6-S1
2. SERVICING SPECIFICATIONS	6-S4
3. TIGHTENING TORQUES	6-S5
4. CHECKING, DISASSEMBLING AND SERVICING.....	6-S6
[1] BATTERY.....	6-S6
(1) Checking.....	6-S6
[2] STARTING SYSTEM	6-S7
(1) Checking.....	6-S7
(2) Disassembling and Assembling	6-S15
(3) Servicing	6-S15
[3] ENGINE SYSTEM	6-S18
(1) Checking.....	6-S18
(2) Disassembling and Assembling	6-S18
(3) Servicing	6-S19
[4] LIGHTING SYSTEM	6-S19
(1) Checking.....	6-S19
[5] GAUGES.....	6-S22
(1) Checking.....	6-S22

1. TROUBLESHOOTING

Symptom	Probable Cause	Solution	Reference Page
All Electrical Equipment Do Not Operate	• Battery discharged or defective	Recharge or Replace	G-17, 1-S11
	• Battery positive cable disconnected or improperly connected	Repair or Replace	—
	• Battery negative cable disconnected or improperly connected	Repair or Replace	—
	• Slow blow fuse blown	Replace	—
Fuse Blown Frequently	• Short-circuited	Repair or Replace	—

W10143220

BATTERY

Battery Discharges Too Quickly	• Battery defective	Replace	1-S11
	• Dynamo defective	Repair or Replace	6-S18, S19
	• IC Regulator defective	Replace	—
	• Wiring harness disconnected or improperly connected (between battery positive terminal and regulator B terminal)	Repair or Replace	—
	• Cooling fan belt slipping	Adjust tension	G-19

W10137180

STARTING SYSTEM

Starter Motor Does Not Operate	• Battery discharged or defective	Recharge or Replace	G-17, 1-S11
	• Slow blow fuse blown	Replace	—
	• Safety switch improperly adjusted or defective	Repair or Replace	6-S10
	• Wiring harness disconnected or improperly connected (between main switch 50 terminal and safety switches, between safety switches and starter motor, between battery positive terminal and starter motor)	Repair or Replace	—
	• Starter motor defective • Main switch defective	Repair or Replace Replace	6-S15 6-S8
Engine Does Not Stop When Main Switch is Turned OFF	• Fuse blown (20 A)	Replace	G-27
	• Wiring harness disconnected or improperly connected (between main switch AC terminal and engine stop solenoid)	Repair or Replace	—
	• Engine stop solenoid defective	Replace	6-S14
Engine Does Not Start	• Engine stop solenoid defective	Replace	6-S14

W10137180

CHARGING SYSTEM

Symptom	Probable Cause	Solution	Reference Page
Charge Lamp Does Not Light when Main Switch is Turned ON	<ul style="list-style-type: none"> • Fuse blown (15 A) • Wiring harness disconnected or improperly connected (between main switch AC terminal and panel board, between panel board and dynamo) 	Replace Repair or Replace	G-27 -
	<ul style="list-style-type: none"> • Dynamo defective • Regulator defective 	Repair or Replace Replace	6-S18, S19 -
Charge Lamp Does Not Go Off When Engine is Running	<ul style="list-style-type: none"> • Wiring harness disconnected or improperly connected (between main switch 30 terminal and dynamo, between panel board and dynamo) 	Repair or Replace	-
	<ul style="list-style-type: none"> • Dynamo defective • Regulator defective 	Repair or Replace Replace	6-S15 -

W10135800

LIGHTING SYSTEM

Head Light Does Not Light	<ul style="list-style-type: none"> • Fuse blown (15 A) • Bulb blown • Wiring harness disconnected or improperly connected (between main switch AC terminal and head light switch, between head light switch and head light) 	Replace Replace Repair or Replace	G-27 G-27 -
Tail Light Does Not Light	<ul style="list-style-type: none"> • Fuse blown (15 A) • Bulb blown • Wiring harness disconnected or improperly connected (between main switch AC terminal and head light switch, between head light switch and tail light) 	Replace Replace Repair or Replace	G-27 G-27 -
Illumination Light Does Not Light	<ul style="list-style-type: none"> • Fuse blown (15 A) • Bulb blown • Wiring harness disconnected or improperly connected (between main switch AC terminal and head light switch, between head light switch and illumination light) 	Replace Replace Repair or Replace	G-27 G-27 -
Hazard Light Does Not Light	<ul style="list-style-type: none"> • Fuse blown (15 A) • Bulb blown • Wiring harness disconnected or improperly connected 	Replace Replace Repair or Replace	G-27 G-27 -
	<ul style="list-style-type: none"> • Flasher unit defective • Hazard switch defective 	Replace Replace	6-S20 6-S20
Hazard Indicator Lamp Does Not Light	<ul style="list-style-type: none"> • Bulb blown • Wiring harness disconnected or improperly connected 	Replace Repair or Replace	- -
Hazard Light Does Not Flicker	<ul style="list-style-type: none"> • Flasher unit defective 	Replace	6-S20

W10137180

LIGHTING SYSTEM (Continued)

Symptom	Probable Cause	Solution	Reference Page
Turn Signal Light Does Not Light	<ul style="list-style-type: none"> • Fuse blown (15 A) • Bulb blown • Wiring harness disconnected or improperly connected • Flasher unit defective • Turn signal switch defective 	Replace Replace Repair or Replace Replace Replace	G-27 G-27 – 6-S20 6-S20
Turn Signal Light Indicator Lamp Does Not Light	<ul style="list-style-type: none"> • Bulb blown • Wiring harness disconnected or improperly connected (turn signal switch and indicator lamp) 	Replace Repair or Replace	– –
Turn Signal Light Does Not Flicker	<ul style="list-style-type: none"> • Flasher unit defective • Turn signal switch defective 	Replace Replace	6-S20 6-S19
Pre-heat Indicator Lamp Does Not Light When Main Switch Is in Pre-heat Position	<ul style="list-style-type: none"> • Battery discharged or defective • Slow blow fuse blown • Wiring harness disconnected or improperly connected (between main switch 19 terminal and pre-heat indicator, between pre-heat indicator and glow plugs) • Main switch defective • Pre-heat indicator defective 	Recharge or Replace Replace Repair or Replace Replace Replace	G-17, 1-S11 – – – –
Oil Pressure Lamp Lights Up When Engine Is Running	<ul style="list-style-type: none"> • Engine oil pressure too low • Engine oil insufficient • Engine oil pressure switch defective • Short circuit between engine oil pressure switch lead and chassis 	Repair engine Replenish Replace Repair	– G-12 6-S21 –
Oil Pressure Lamp Does Not Light When Main Switch Is Turned ON and Engine Is Not Running	<ul style="list-style-type: none"> • Bulb blown • Engine oil pressure switch defective • Wiring harness disconnected or improperly connected (between panel board and engine oil pressure switch) 	Replace Replace Repair or Replace	– 6-S21 –

W10135800

GAUGES

Fuel Gauge Does Not Function	<ul style="list-style-type: none"> • Fuel gauge defective • Fuel level sensor defective • Wiring harness disconnected or improperly connected (between fuel gauge and fuel level sensor) 	Replace Replace Repair or Replace	6-S22 6-S22 –
Coolant Temperature Gauge Does Not Function	<ul style="list-style-type: none"> • Coolant temperature gauge defective • Coolant temperature sensor defective • Wiring harness disconnected or improperly connected (between coolant temperature gauge and coolant temperature sensor) 	Replace Replace Repair or Replace	6-S22 6-S22 –

W10137180

2. SERVICING SPECIFICATIONS

Item		Factory Specification	Allowable Limit
Battery	Voltage	More than 12 V	—
	Potential Difference	Less than 0.1 V	—
Safety Switch	Distance	7.0 mm 0.276 in.	—
OPC Switch	Distance	12 mm 0.472 in.	—
Glow Plug	Resistance	Approx. 0.9 Ω	—
Starter	Commutator	O.D.	30.0 mm 1.181 in.
		Difference of O.D.'s	Less than 0.02 mm 0.0008 in.
	Mica	Under Cut	0.50 to 0.80 mm 0.0197 to 0.0315 in.
	Brush	Length	14.0 mm 0.551 in.
AC Dynamo	Charging Current / Dynamo Speed	14 to 15 A / 5200 min ⁻¹ (rpm)	—
	Charging Voltage / Dynamo Speed	14 to 15 A / 5200 min ⁻¹ (rpm)	—
Head Light Switch	Resistance OFF	Infinity	—
	ON	0 Ω	—
Turn Signal Switch	Resistance OFF	Infinity	—
	R	0 Ω	—
	L	0 Ω	—
Hazard Light Switch	Resistance OFF	Infinity	—
	ON	0 Ω	—

W10138740

3. TIGHTENING TORQUES

Tightening torques of screws, bolts and nuts on the table below are especially specified.
 (For general use screws, bolts and nuts : See page G-8.)

Item	N·m	kgf·m	ft-lbs
Starter B terminal nut	5.9 to 11.8	0.6 to 1.2	4.3 to 8.7
AC Dynamo Stator nut	39.2 to 44.1	4.0 to 4.5	28.9 to 32.5

W10127360

4. CHECKING, DISASSEMBLING AND SERVICING

⚠ CAUTION

- To avoid accidental short circuit, be sure to attach the positive cable to the positive terminal before the negative cable is attached to the negative terminal.
- Never remove the battery cap while the engine is running.
- Keep electrolyte away from eyes, hands and clothes. If you are splattered with it, wash it away completely with water immediately.
- Keep open sparks and flames away from the battery at all times. Hydrogen gas mixed with oxygen becomes very explosive.

■ IMPORTANT

- If the machine is to be operated for a short time without battery (using a slave battery for starting), use additional current (lights) while engine is running and insulate terminal of battery. If this advice is disregarded, damage to alternator and regulator may result.

[1] BATTERY

(1) Checking

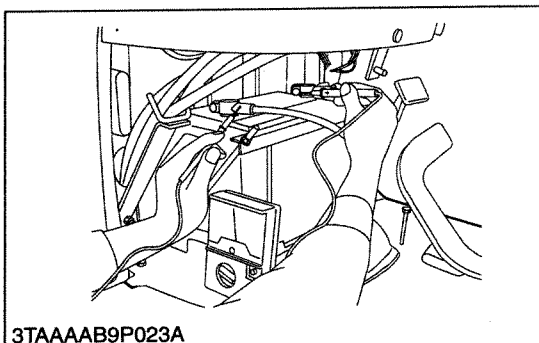

Battery Voltage

1. Stop the engine and turn the main switch off.
2. Connect the COM (-) lead of the voltmeter to the battery's negative terminal post and the (+) lead to the positive terminal post, and measure the battery voltage.
3. If the battery voltage is less than the factory specification, check the battery specific gravity and recharge the battery.

Battery voltage	Factory spec.	More than 12 V
-----------------	---------------	----------------

W10125620

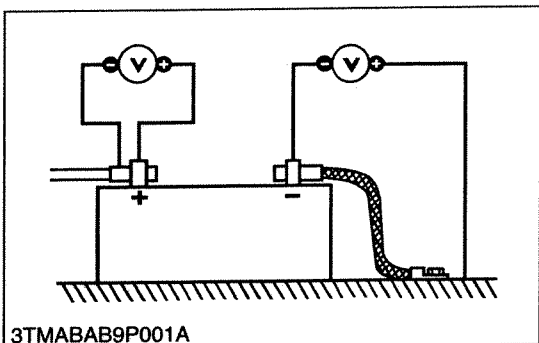

Battery Terminal Connection

1. Turn the main switch on, and turn on the head light.
2. Measure the voltage with a voltmeter across the battery's positive terminal post and the cable terminal, and the voltage across the battery's negative terminal post and the chassis.
3. If the measurement exceeds the factory specification, clean the battery terminal posts and cable clamps, and tighten them firmly.

Potential difference	Factory spec.	Less than 0.1 V
----------------------	---------------	-----------------

W10126630

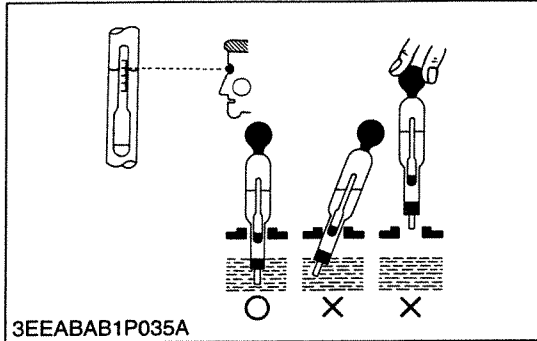
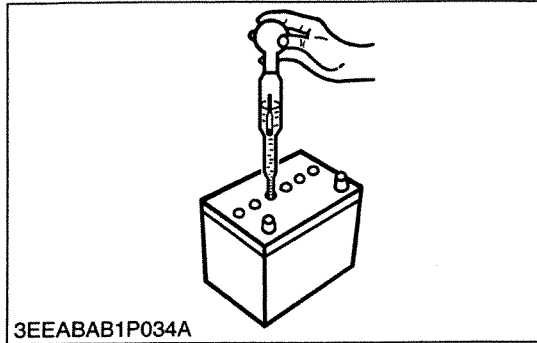

Battery Specific Gravity

1. Check the specific gravity of the electrolyte in each cell with a hydrometer.
2. When the electrolyte temperature differs from that at which the hydrometer was calibrated, correct the specific gravity reading following the formula mentioned in (Reference).
3. If the specific gravity is less than 1.215 (after it is corrected for temperature), charge or replace the battery.
4. If the specific gravity differs between any two cells by more than 0.05, replace the battery.

NOTE

- Hold the hydrometer tube vertical without removing it from the electrolyte.
- Do not suck too much electrolyte into the tube.
- Allow the float to move freely and hold the hydrometer at eye level.
- The hydrometer reading must be taken at the highest electrolyte level.

(Reference)

- Specific gravity slightly varies with temperature. To be exact, the specific gravity decreases by 0.0007 with an increase of 1 °C (0.0004 with an increase of 1 °F) in temperature, and increases by 0.0007 with a decreases of 1 °C (0.0004 with a decrease of 1 °F).

Therefore, using 20 °C (68 °F) as a reference, the specific gravity reading must be corrected by the following formula :

- Specific gravity at 20 °C = Measured value + 0.0007 × (electrolyte temperature – 20 °C)
- Specific gravity at 68 °F = Measured value + 0.0004 × (electrolyte temperature – 68 °F)

Specific Gravity	State of Charge
1.260 Sp. Gr.	100 % Charged
1.230 Sp. Gr.	75 % Charged
1.200 Sp. Gr.	50 % Charged
1.170 Sp. Gr.	25 % Charged
1.140 Sp. Gr.	Very Little Useful Capacity
1.110 Sp. Gr.	Discharged

At an electrolyte temperature of 20 °C (68 °F)

W10127630

[2] STARTING SYSTEM

(1) Checking

(A) Main Switch

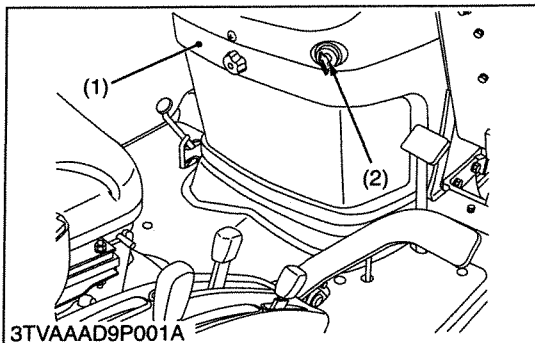

Main Switch

1. Remove the under panel (1).
2. Disconnect the 4P connector and remove the main switch (2).
3. Perform the following checks.

(1) Under Panel

(2) Main Switch

W10134520

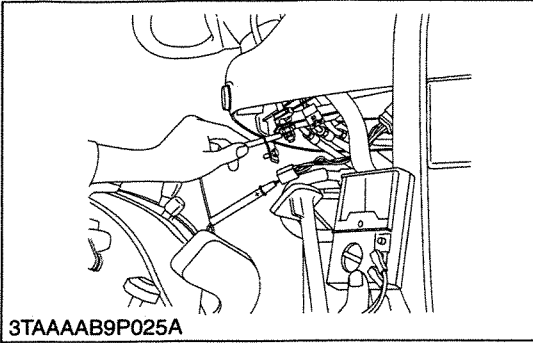

3TAAAAB9P025A

Connector Voltage

1. Measure the voltage with a voltmeter across the connector **30** (red) terminal and chassis.
2. If the voltage differs from the battery voltage (11 to 14 V), the wiring harness is faulty.

Voltage	Connector 30 terminal – chassis	Approx. battery voltage
---------	--	-------------------------

W10135530

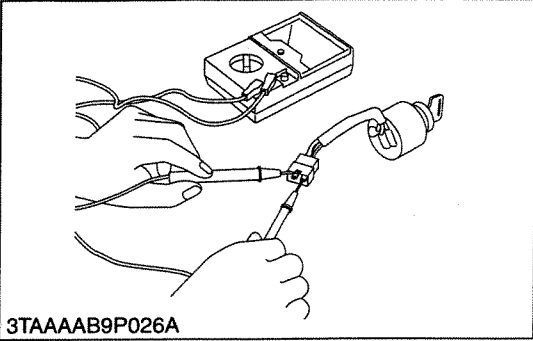

3TAAAAB9P026A

Main Switch Continuity

1) Main Switch Key at OFF Position

1. Set the main switch **OFF** position.
2. Measure the resistance with an ohmmeter across the **30** terminal and the **AC** terminal, **30** terminal and **50** terminal, **30** terminal and **19** terminal.
3. If infinity is not indicated, the contacts of the main switch are faulty.

Resistance	30 terminal – AC terminal	Infinity
	30 terminal – 50 terminal	
	30 terminal – 19 terminal	

2) Main Switch Key at ON Position

1. Set the main switch **ON** position.
2. Measure the resistance with an ohmmeter across the **30** terminal and the **AC** terminal.
3. If 0 ohm is not indicated, the **30 – AC** contact of the main switch are faulty.

Resistance	30 terminal – AC terminal	0 Ω
------------	---------------------------	-----

3) Main Switch Key at PREHEAT Position

1. Set and hold the main switch key at the **PREHEAT** position.
2. Measure the resistance with an ohmmeter across the **30** terminal and the **19** terminal, and measure the resistance across the **30** terminal and the **AC** terminal.
3. If 0 ohm is not indicated, these contacts of the main switch are faulty.

Resistance	30 terminal – 19 terminal	0 Ω
	30 terminal – AC terminal	

4) Main Switch Key at START Position

1. Set and hold the main switch key at the **START** position.
2. Measure the resistance with an ohmmeter across the **30** terminal and the **19** terminal, across the **30** terminal and the **50** terminal, and across the **30** terminal and the **AC** terminal.
3. If 0 ohm is not indicated, these contacts of the main switch are faulty.

Resistance	30 terminal – 19 terminal	0 Ω
	30 terminal – 50 terminal	
	30 terminal – AC terminal	

- (1) 19 Terminal (Black / Red)
- (2) AC Terminal (Red / White)
- (3) 50 Terminal (Black / White)
- (4) 30 Terminal (Red)

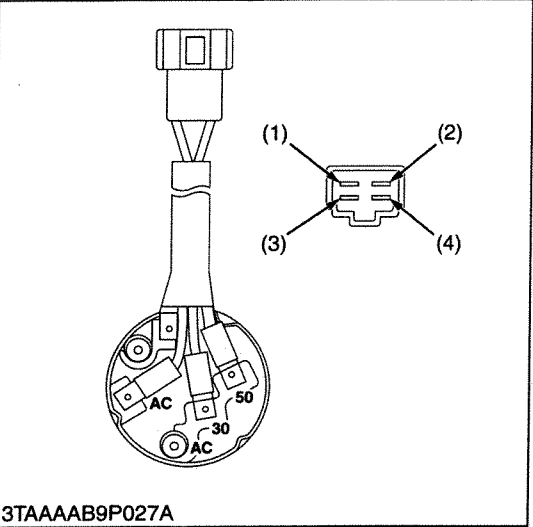

3TAAAAB9P027A

W10136580

(B) Starter

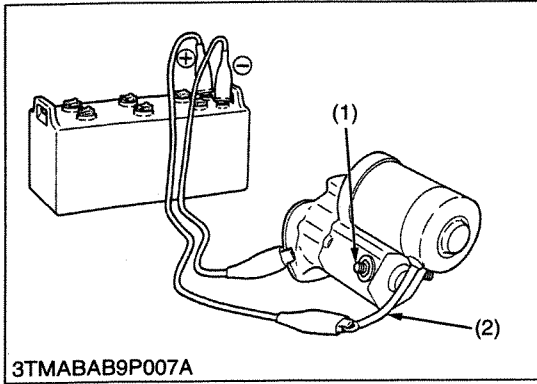

Motor Test

⚠ CAUTION

- **Secure the starter to prevent it from jumping up and down while testing the motor.**
- 1. Disconnect the battery negative cable from the battery.
- 2. Disconnect the battery positive cable and the leads from the starter.
- 3. Remove the starter from the engine.
- 4. Disconnect the connecting lead (2) from the starter C terminal (1).
- 5. Connect a jumper lead from the connecting lead (2) to the battery positive terminal post.
- 6. Connect a jumper lead momentarily between the starter motor housing and the battery negative terminal post.
- 7. If the motor does not run, check the motor.

(1) C Terminal (2) Connecting Lead

W10142670

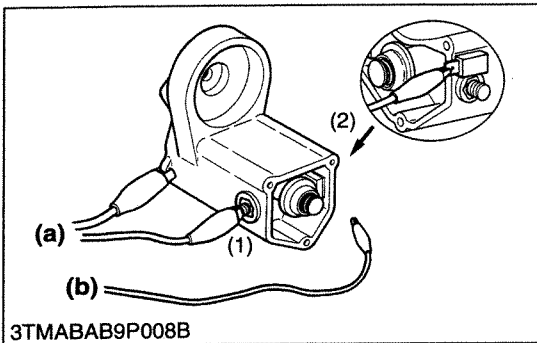

Magnet Switch Test (Pull-in, Holding Coils)

1. Remove the motor from the starter housing.
2. Prepare a 6 V battery for the test.
3. Connect jumper leads from the battery negative terminal to the housing and the starter C terminal (1).
4. The plunger should be attracted and the pinion gear should pop out when a jumper lead is connected from the battery positive terminal to the S terminal (2). It's correct.
5. Disconnect the jumper lead to the starter C terminal (1). Then the pinion gear should remain popped out. It's a correct.

■ IMPORTANT

- **Testing time must be 3 to 5 sec..**

(1) C Terminal (a) To Negative Terminal
 (2) S Terminal (b) To Positive Terminal

W1015210

(C) Glow Plug

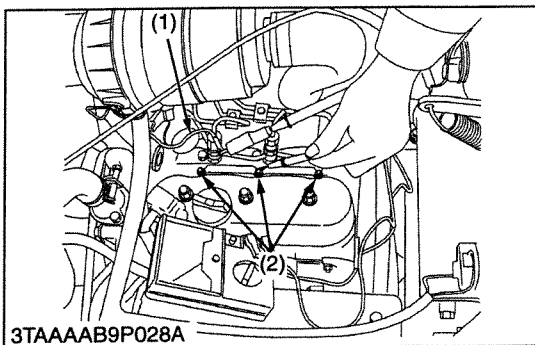

Lead Terminal Voltage

1. Disconnect the wiring lead (1) from the glow plug (2) after turning the main switch off.
2. Turn the main switch key to the "PREHEAT" position, and measure the voltage between the lead terminal and the chassis.
3. Turn the main switch key to the "START" position, and measure the voltage with a voltmeter between the lead terminal and the chassis.
4. If the voltage at either position differs from the battery voltage, the wiring harness or main switch is faulty.

Voltage (Lead terminal – Chassis)	Main switch key at "PREHEAT"	Approx. battery voltage
	Main switch key at "START"	Approx. battery voltage

(1) Wiring Lead (Positive) (2) Glow Plug

W10149130

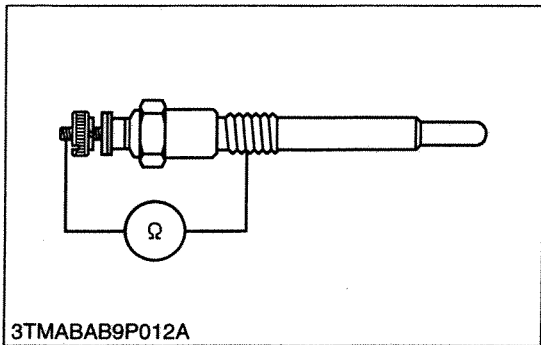

3TMABAB9P012A

Glow Plug Continuity

1. Disconnect the lead from the glow plugs.
2. Measure the resistance with an ohmmeter between the glow plug terminal and the chassis.
3. If 0 ohm is indicated, the screw at the tip of the glow plug and the housing are short-circuited.
4. If the factory specification is not indicated, the glow plug is faulty.

Glow plug resistance	Factory spec.	Approx. 0.9 Ω
----------------------	---------------	---------------

W10151150

(D) Safety Switch

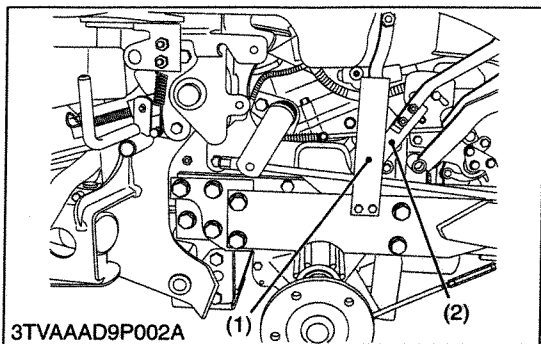

3TVAAAD9P002A

Safety Switch Continuity

1) Range Gear Shift Lever Switch

1. Remove the rear wheel RH.
2. Remove the seat belt stay RH (1).
3. Remove the range gear shift lever (2).
4. Disconnect the feed back rod (4) from the hydraulic control lever.
5. Remove the safety switch stay mounting bolts (3).
6. Remove the safety switch (6) while installed in the safety switch stay (7).
7. Measure the resistance with an ohmmeter across the safety switch terminals (5).
8. If the safety switch is defective, replace it.

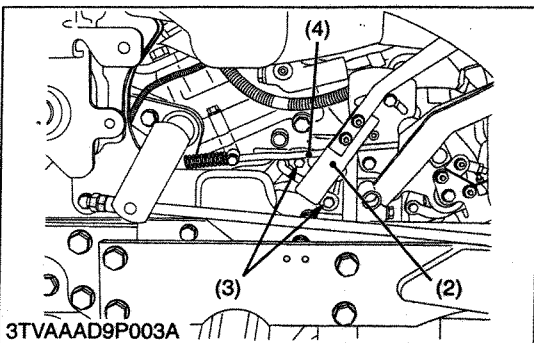

3TVAAAD9P003A

Resistance (Across switch terminal)	When switch push is pushed	0 Ω
	When switch push is released	Infinity

- | | |
|--------------------------------------|--|
| (1) Seat Belt Stay RH | (5) Safety Switch Terminal |
| (2) Range Gear Shift Lever | (6) Safety Switch for Range Gear Shift Lever |
| (3) Safety Switch Stay Mounting Bolt | (7) Safety Switch Stay |
| (4) Feed Back Rod | |

W10158610

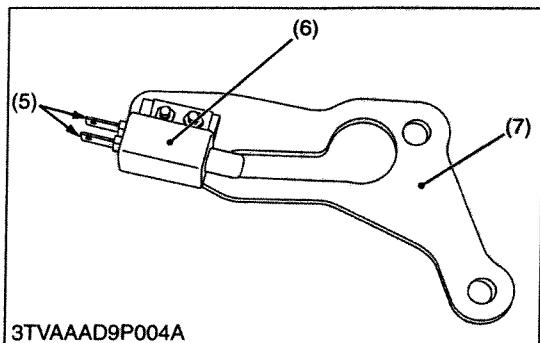

3TVAAAD9P004A

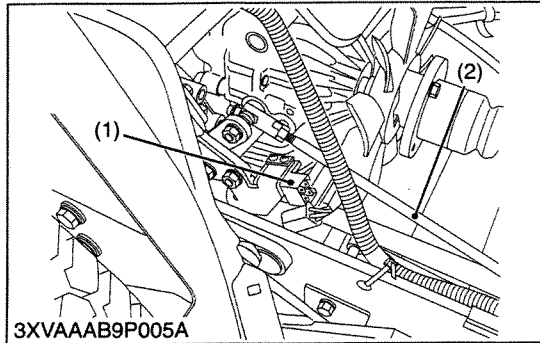

3XVAAAB9P005A

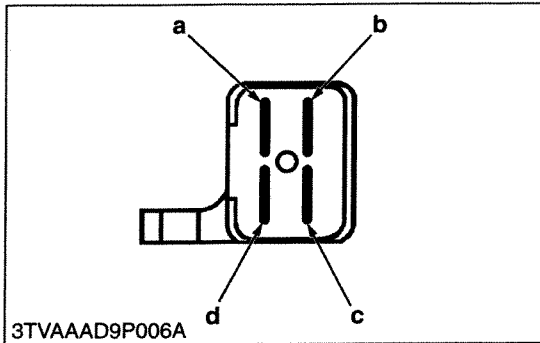

3TVAAAD9P006A

2) HST Trunnion Switch

1. Remove the battery. (See page 2-S13.)
2. Remove the seat. (See page 2-S14.)
3. Remove the speed control pedal, lever guides and step. (See page 2-S14.)
4. Remove the safety switch (1) lead.
5. Measure the resistance between terminal **a** and terminal **b**, and the resistance between terminal **c** and terminal **d** with an ohmmeter.
6. If the safety switch is defective, replace it.

Resistance (between terminal a and b)	When switch push is pushed	0 Ω
	When switch push is released	Infinity
Resistance (between terminal c and d)	When switch push is pushed	0 Ω
	When switch push is released	Infinity

- (1) Safety Switch for HST Trunnion **a to d :Safety Switch Terminal**
 (2) Speed Control Rod

W10198720

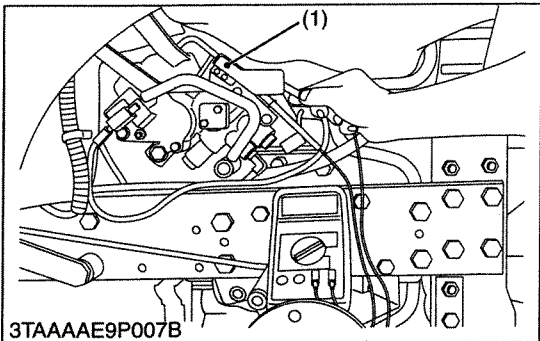

3TAAAAE9P007B

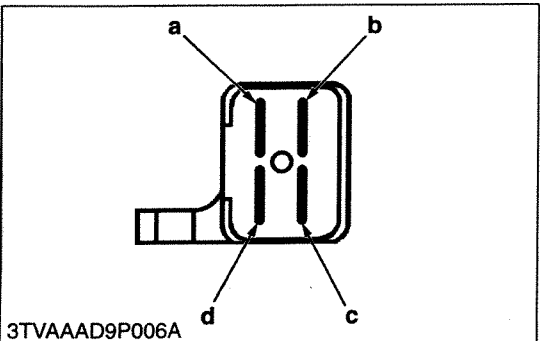

3TVAAAD9P006A

3) PTO Clutch Lever Switch

1. Remove the rear wheel LH.
2. Remove the safety switch lead.
3. Measure the resistance between terminal **a** and terminal **b**, and the resistance between terminal **c** and terminal **d** with an ohmmeter.
4. If the safety switch is defective, replace it.

Resistance (between terminal a and b)	When switch push is pushed	0 Ω
	When switch push is released	Infinity
Resistance (between terminal c and d)	When switch push is pushed	0 Ω
	When switch push is released	Infinity

- (1) Safety Switch for PTO Clutch Lever **a to d :Safety Switch Terminal**

W10211170

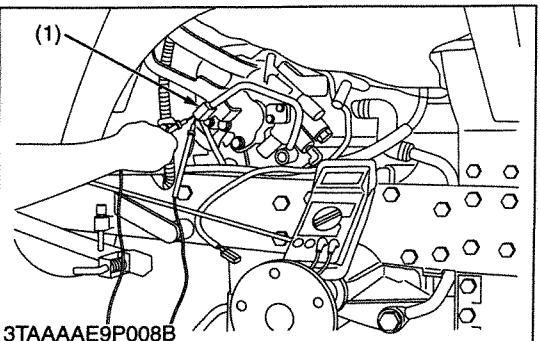

3TAAAAE9P008B

4) PTO Select Lever Switch

1. Remove the rear wheel LH.
2. Remove the safety switch lead.
3. Measure the resistance with an ohmmeter across the safety switch terminals (as shown the figure).
4. If the safety switch is defective, replace it.

Resistance (Across switch terminals)	When switch push is pushed	0 Ω
	When switch push is released	Infinity

- (1) Safety Switch for PTO Select Lever

W10213340

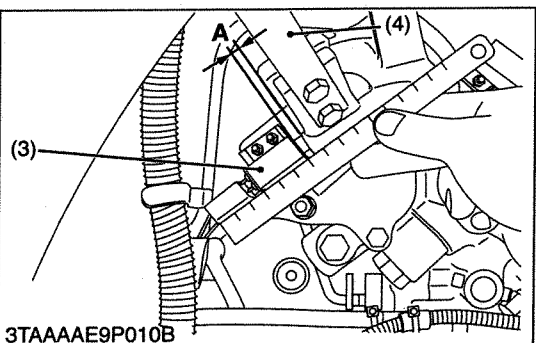
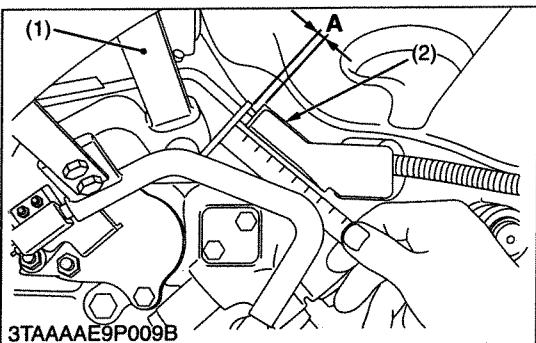
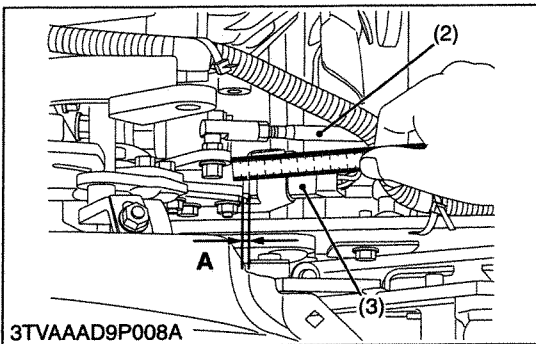
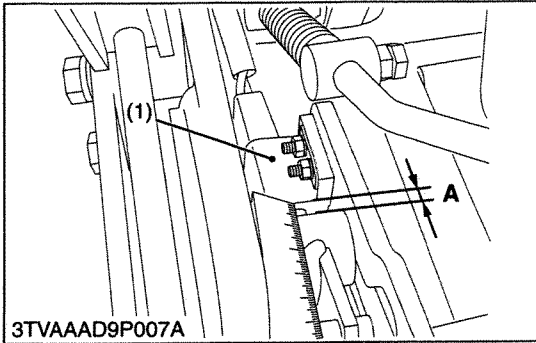

Safety Switch Distance

1) Range Gear Shift Lever Switch and HST Trunnion Switch

1. Remove the battery. (See page 2-S13.)
2. Remove the seat and the ROPS. (See page 2-S14.)
3. Remove the speed control pedal, lever guides and step. (See page 2-S14.)
4. Remove the fender RH.
5. After removing the step, reinstall the speed control pedal.
6. Set the range gear shift lever and speed control pedal to "Neutral" position.
7. Measure the distance **A**.
8. If the measurement is not same as the factory specification, adjust the distance **A** by moving the safety switch mounting location.

Safety switch distance "A"	Factory spec.	7 mm 0.276 in.
----------------------------	---------------	-------------------

- (1) Safety Switch for Range Gear Shift Lever
 (2) Speed Control Rod
 (3) Safety Switch for HST Trunnion

W1015919

2) PTO Clutch Lever Switch and PTO Select Lever Switch

1. Remove the rear wheel LH.
2. Set the PTO clutch lever to "Disengaged" position and the PTO select lever to "Neutral" position.
3. Measure the distance **A**.
4. If the measure is not same as the factory specification, adjust the distance **A** by moving the safety switch mounting location.

Safety switch distance "A"	Factory spec.	7 mm 0.276 in.
----------------------------	---------------	-------------------

- (1) PTO Clutch Lever
 (2) Safety Switch for PTO Clutch Lever
 (3) Safety Switch for PTO Select Lever
 (4) PTO Select Lever

W1024743

(E) Operator Presence Control (OPC) Switch

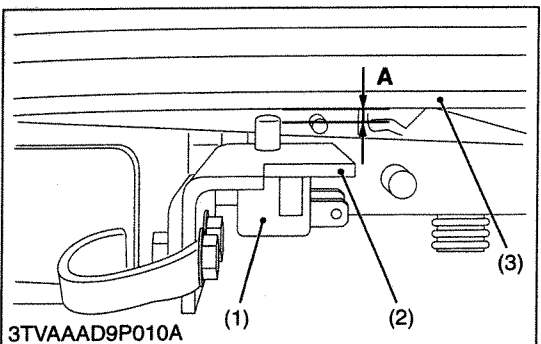
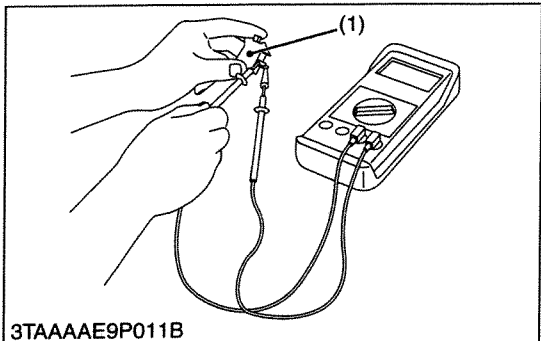
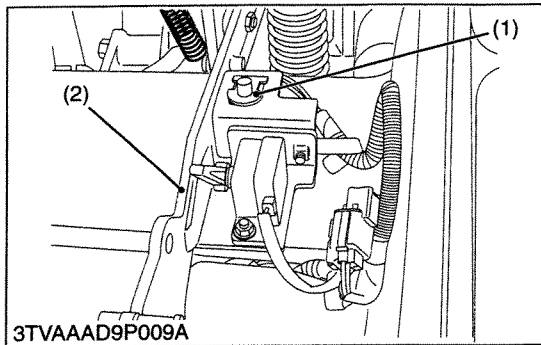

OPC Switch (Seat Switch) Continuity

1. Remove the OPC switch (1).
2. Measure the resistance with an ohmmeter across the OPC switch terminals.
3. If the OPC switch (1) is defective, replace it.

Resistance (Across switch terminal)	When switch push is pushed	0 Ω
	When switch push is released	Infinity

- (1) OPC Switch (Seat Switch) (2) Seat Support

W1025909

OPC Switch (Seat Switch) Distance

1. Measure the distance **A** when the seat is vacant.
2. If the measurement is not same as the factory specification, adjust the distance **A** by moving the seat switch bracket location.

Distance "A"	Factory spec.	12 mm 0.472 in.
--------------	---------------	--------------------

- (1) OPC Switch (Seat Switch) **A : Distance**
 (2) Seat Switch Stay
 (3) Seat Rail

W1027139

(F) Fuel Pump

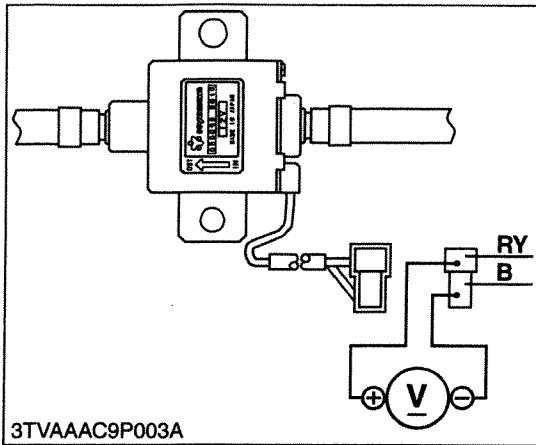

Connector Voltage

1. Disconnect the **2P** connector from the fuel pump.
2. Turn the main switch key to the **“ON”** position, and measure the voltage with a voltmeter between the connector terminals.
3. If the voltage differs from the battery voltage, the wiring harness or main switch is faulty.

Voltage	Between connector terminal	Approx. battery voltage
---------	----------------------------	-------------------------

W1016341

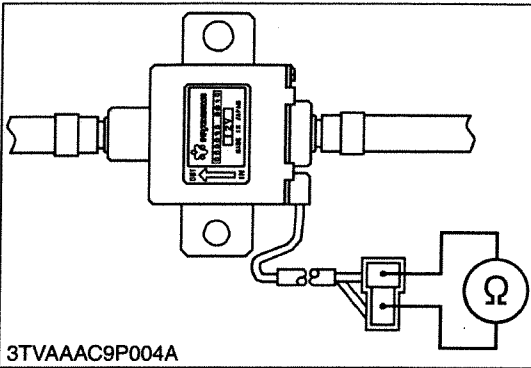

Fuel Pump Continuity

1. Disconnect the **2P** connector from the fuel pump.
2. Check the continuity between the connector terminals with an ohmmeter.
3. If it does not conduct, the fuel pump is faulty.

W1016134

(G) Engine Stop Solenoid

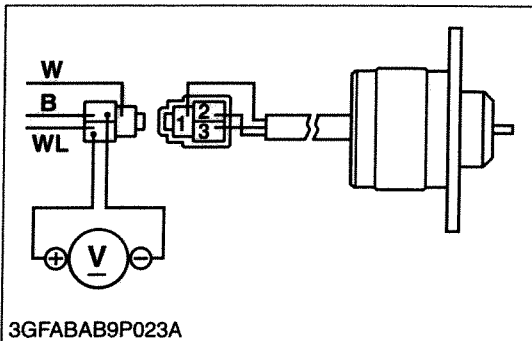

Connector Voltage

1. Disconnect the **3P** connector from the engine stop solenoid.
2. Turn the main switch key to the **“ON”** position, and measure the voltage with a voltmeter between the terminal **3** (Red / Black) and the terminal **2** (Black).
3. If the voltage differs from the battery voltage, the wiring harness or main switch is faulty.

Voltage	Terminal 3 - Terminal 2	Approx. battery voltage
---------	-------------------------	-------------------------

W1016508

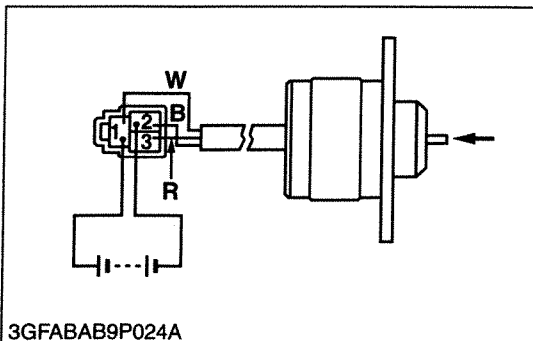

Engine Stop Solenoid Test

1. Disconnect the **3P** connector from the engine stop solenoid.
2. Remove the engine stop solenoid from the engine.
3. Connect the jumper leads from the battery positive terminal to the terminal **1** (White), and from the battery negative terminal to the terminal **2** (Black).
4. If the solenoid plunger is not attracted, the engine stop solenoid is faulty.
5. Connect the jumper leads from the battery positive terminal to the terminal **3** (Red), and from the battery negative terminal to the terminal **2** (Black). Push the solenoid plunger in by your finger, and then release it.
6. If the solenoid plunger is not held, the engine stop solenoid is faulty.

W1016653

(2) Disassembling and Assembling

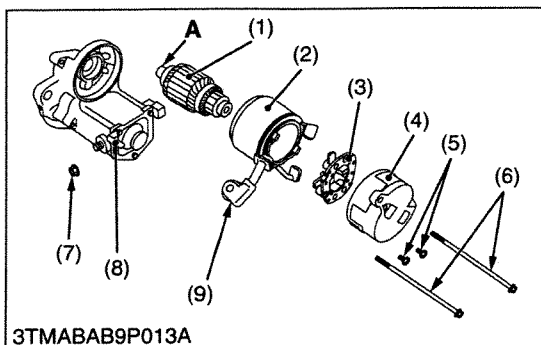

Disassembling Motor

1. Disconnect the connecting lead (9) from the magnet switch (8).
2. Remove the screws (6), and then separate the end frame (4), yoke (2) and armature (1).
3. Remove the two screws (5), and then take out the brush holder (3) from the end frame (4).

(When reassembling)

- Apply grease to the spline teeth (A) of the armature (1).

Tightening torque	Nut (7)	5.9 to 11.8 N·m 0.6 to 1.2 kgf·m 4.3 to 8.7 ft·lbs
-------------------	---------	--

- | | |
|------------------|-------------------------|
| (1) Armature | (7) Nut |
| (2) Yoke | (8) Magnet Switch |
| (3) Brush Holder | (9) Connecting Lead |
| (4) End Frame | |
| (5) Screw | A : Spline Teeth |
| (6) Screw | |

W1016288

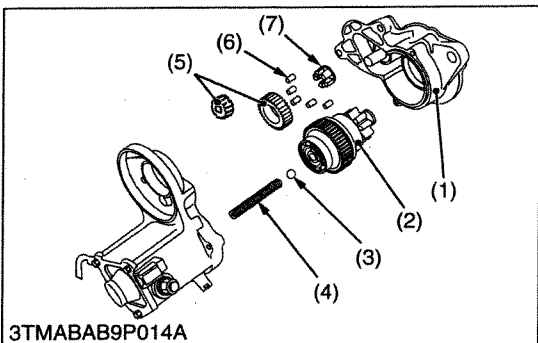

Disassembling Magnet Switch

1. Remove the drive end frame (1) mounting screws.
2. Take out the overrunning clutch (2), ball (3), spring (4), gears (5), rollers (6) and retainer (7).

(When reassembling)

- Apply grease to the gear teeth of the gears (5) and overrunning clutch (2), and ball (3).

- | | |
|------------------------|--------------|
| (1) Drive End Frame | (5) Gear |
| (2) Overrunning Clutch | (6) Roller |
| (3) Ball | (7) Retainer |
| (4) Spring | |

W1016728

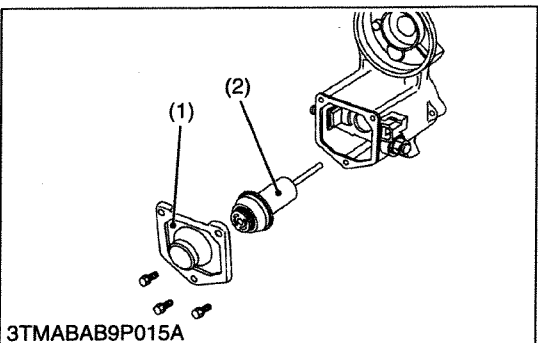

Plunger

1. Remove the end cover (1).
2. Take out the plunger (2).

- | | |
|---------------|-------------|
| (1) End Cover | (2) Plunger |
|---------------|-------------|

W1016883

(3) Servicing

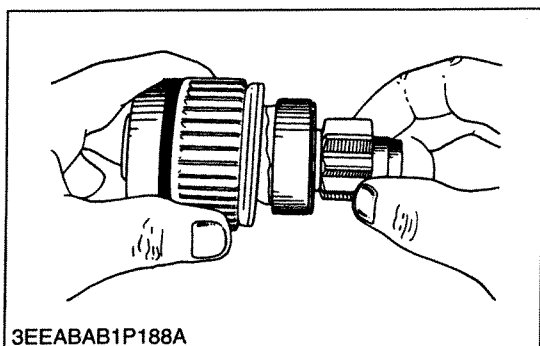

Overrunning Clutch

1. Inspect the pinion for wear or damage.
2. If there is any defect, replace the overrunning clutch assembly.
3. Check that the pinion turns freely and smoothly in the overrunning direction and does not slip in the cranking direction.
4. If the pinion slips or does not rotate in the both directions, replace the overrunning clutch assembly.

W1016990

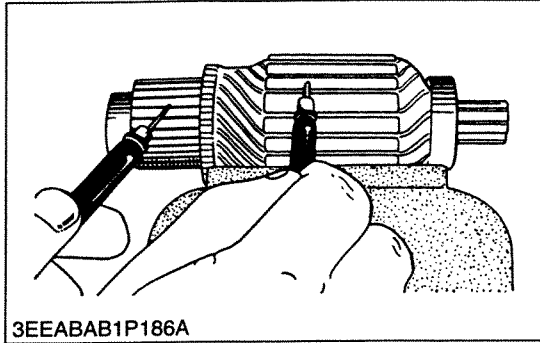

Armature Coil

1. Check the continuity across the commutator and armature coil core with an ohmmeter.
2. If it conducts, replace the armature.
3. Check the continuity across the segments of the commutator with an ohmmeter.
4. If it does not conduct, replace the armature.

W1017767

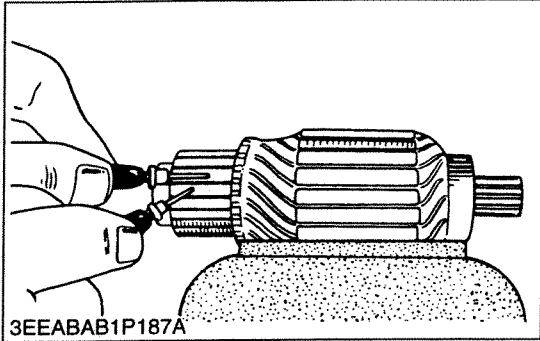

Field Coil

1. Check the continuity across the lead (1) and brush (2) with an ohmmeter.
2. If it does not conduct, replace the yoke assembly.
3. Check the continuity across the brush (2) and yoke (3) with an ohmmeter.
4. If it conducts, replace the yoke assembly.

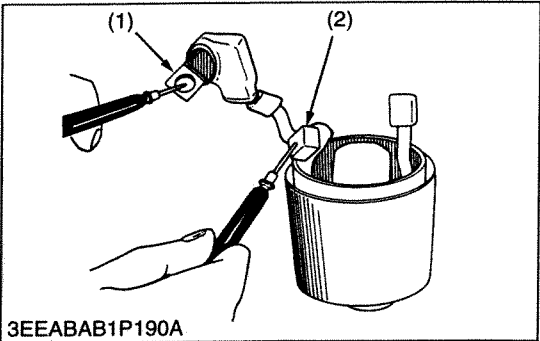

- (1) Lead
- (2) Brush

- (3) Yoke

W1018015

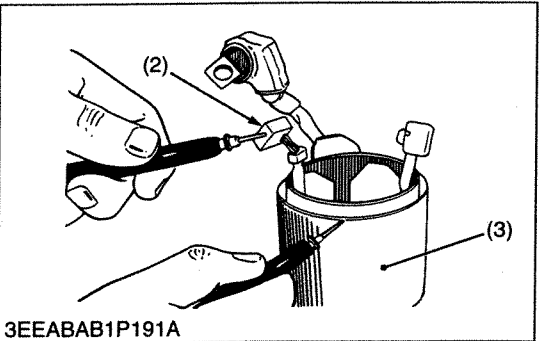

[3] CHERGINE SYSTEM

(1) Checking

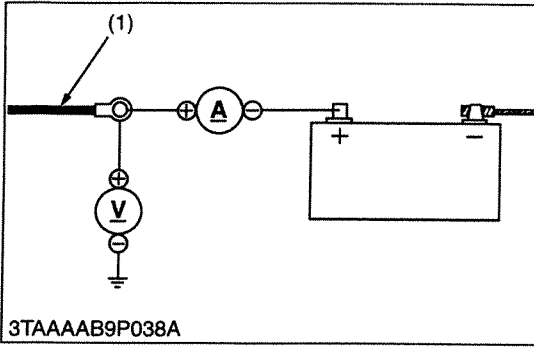

Battery Charging Current

1. After starting the engine, disconnect the battery positive cord (+), and connect an ammeter and voltmeter. Then switch on all electrical loads (such as head lights) and measure the charging current.

■ **NOTE**

- Connect an ammeter only after starting the engine.
- When the electrical loads is considerably low or the battery is fully charged, the specified reading may not be obtained.

Factory spec.	Current	14 to 15 V
	Voltage	14 to 15 V
	Dynamo speed	5200 min ⁻¹ (rpm)

(1) Battery Positive Cord

W1018053

Continuity across Regulator's Terminals

1. Remove the regulator coupler.
2. Check with a tester whether the regulator is in optimum condition or not.

■ **Check Table**

■ **NOTE**

- Type to use a high-resistance tester as far as possible.
- The judgement should be as below table. "ON" if the indicator moves, otherwise "OFF".

Tester + terminal	Cord colors					
	Blue	Black	Blue	Green	Yellow	Red
Tester - terminal						
Cord colors	Blue	OFF	ON	ON	ON	ON
	Black	ON	ON	ON	ON	ON
	Blue	ON	OFF	ON	ON	ON
	Green	OFF	OFF	OFF	OFF	OFF
	Yellow	OFF	OFF	OFF	OFF	OFF
	Red	ON	OFF	ON	ON	ON

- (1) Blue
(2) Black
(3) Blue

- (4) Green
(5) Yellow
(6) Red

W1018232

(2) Disassembling and Assembling

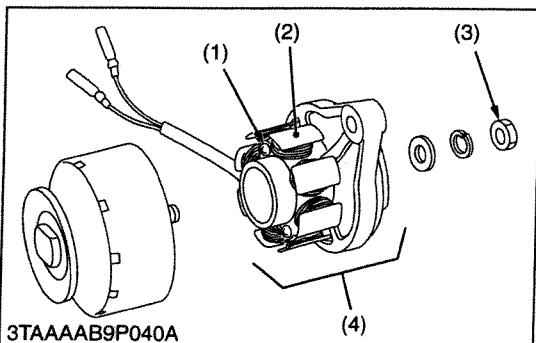

Stator

1. Remove the nut (3) and separate the stator comp. (4).
2. Unscrew the screws (1) and remove the stator (2).

(When reassembling)

Tightening torque	Nut	39.2 to 44.1 N·m 4.0 to 4.5 kgf·m 28.9 to 32.5 ft·lbs
-------------------	-----	---

- (1) Screw
(2) Stator

- (3) Nut
(4) Stator Comp.

W1018872

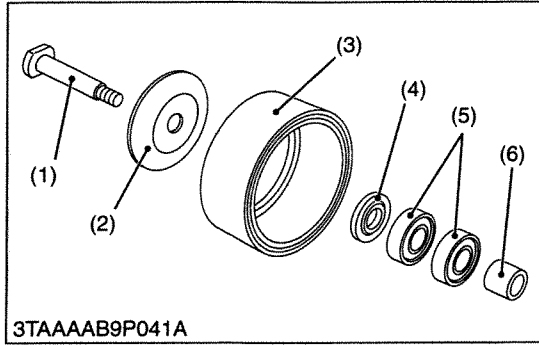

3TAAAAB9P041A

Rotor

1. Tap out the shaft (1) from the rotor (3).

(When reassembling)

- Take care the direction of the collar (4), the flat side should face to the pulley (2) side.

- | | |
|------------|--------------|
| (1) Shaft | (4) Collar |
| (2) Pulley | (5) Bearings |
| (3) Rotor | (6) Collar |

W1019015

(3) Servicing

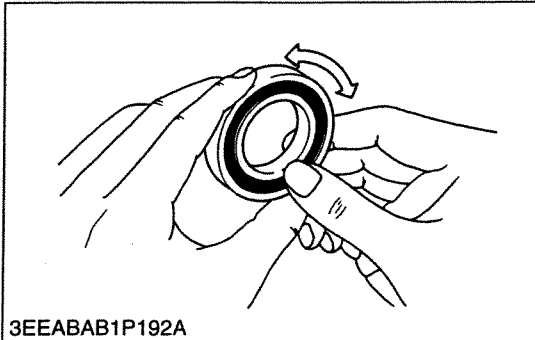

3EEABAB1P192A

Bearing

1. Check the bearing for smooth rotation.
2. If it does not rotate smoothly, replace it.

W1019790

[4] LIGHTING SYSTEM

(1) Checking

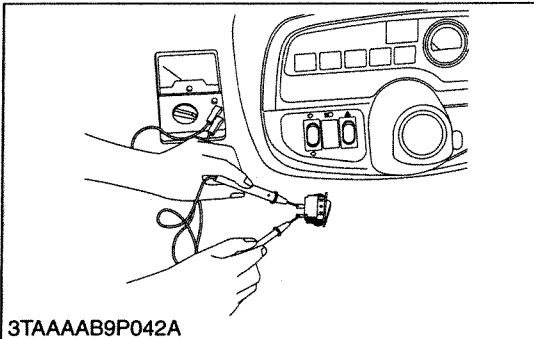

3TAAAAB9P042A

Head Light Switch Continuity

1. Remove the under panel.
2. Disconnect the wiring leads from head light switch and remove it.
3. Measure the resistance with an ohmmeter across the head light switch terminals in each position.
4. If the resistance differs from the factory specifications, the head light switch is faulty.

Resistance	Factory spec.	OFF	Infinity
		ON	0 Ω

W1019360

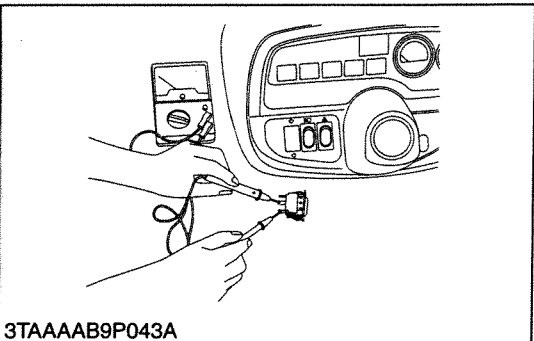

3TAAAAB9P043A

Turn Signal Switch Continuity

1. Remove the under panel.
2. Disconnect the connector from turn signal switch and remove it.
3. Measure the resistance with an ohmmeter across the center terminal and terminal R or L.
4. If the resistance differs from the factory specifications, the turn signal switch is faulty.

Resistance	Factory spec.	OFF	Infinity
		R	0 Ω
		L	0 Ω

W1019512

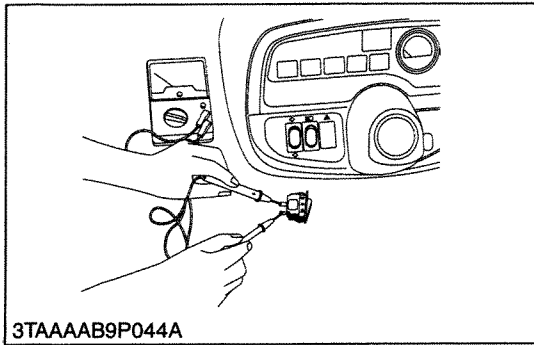

Hazard Light Switch Continuity

1. Remove the under panel.
2. Disconnect the wiring leads from hazard light switch and remove it.
3. Measure the resistance with an ohmmeter across the hazard light switch terminals in each position.
4. If the resistance differs from the factory specifications, the hazard light switch is faulty.

Resistance	Factory spec.	OFF	Infinity
		ON	0 Ω

W1019697

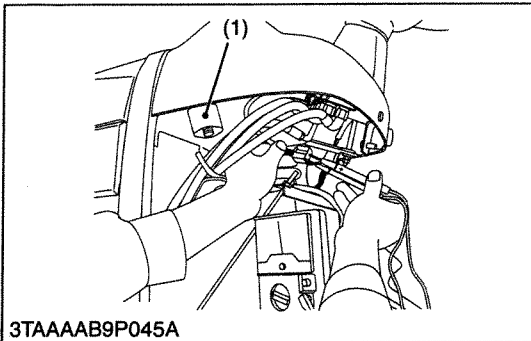

Flasher Unit

1. Remove the under panel.
2. Disconnect the coupler from flasher unit.
3. Measure the voltage with a voltmeter across the terminal **h** and terminal **c** or chassis.
4. If the voltage differ from the battery voltage, the wiring harness is faulty.

Voltage	Terminal h – Terminal c or Chassis	Approx. battery voltage
---------	--	-------------------------

(1) Flasher Unit

W1019868

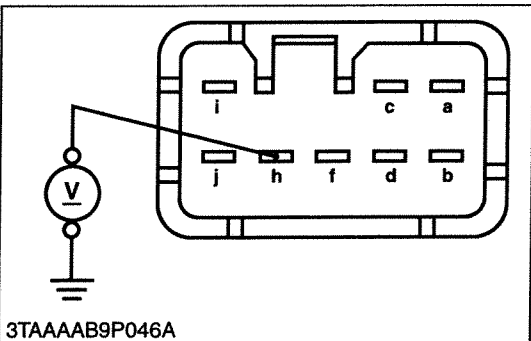

Flasher Unit Actuation Test

1. Set the hazard switch to the **ON** position, and make sure the hazard light gives 60 to 85 flashes for a minute.
2. With the main switch and the hazard switch at the **ACC** and **ON** positions, respectively, move the turn signal switch to the left. Make sure that the right-hand light stays on and the left-hand light gives flashes earlier (by about 20 flashes) than when the hazard lamp is activated. Then move the turn signal switch to the right and make sure the corresponding actions take place.
3. Now set the main switch to the **ACC** position and move the turn signal switch alone. Make sure the same actions as above result.
4. If both the hazard switch and the turn signal switch function but the above actions do not take place, replace the flasher unit with new one.

(1) Hazard Switch
 (2) Turn Signal Switch

(3) Flasher Unit

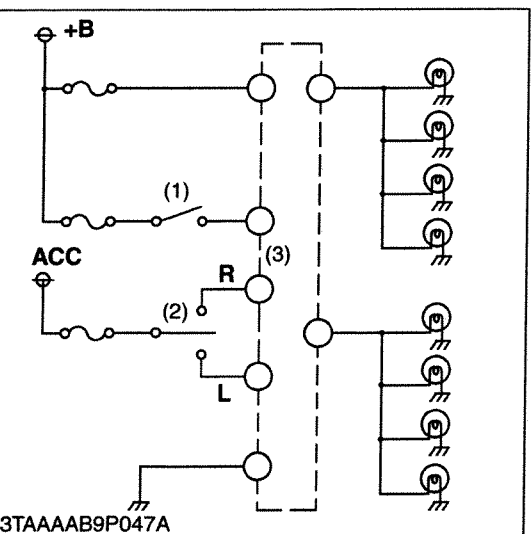

W1020049

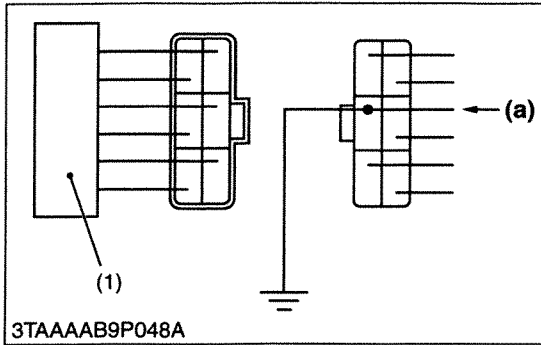

Charge Lamp (Charging Circuit)

1. Remove the under panel.
2. Disconnect the **6P** connector from the regulator after turning the main switch **OFF**.
3. Turn the main switch **ON** and connect a jumper lead from the wiring harness connector terminal (Black) to the chassis.
4. If the charge lamp does not light, the wiring harness or fuse is faulty.

(1) Regulator

(a) From Charge Lamp

W1020208

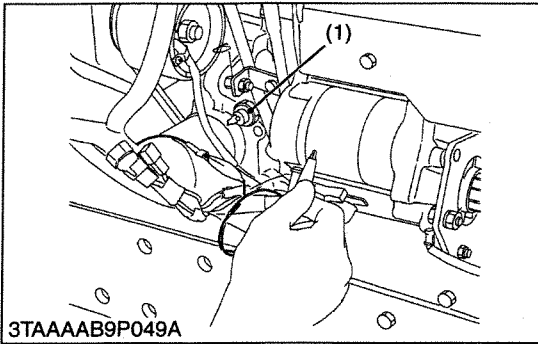

Engine Oil Pressure Lamp

1. Disconnect the lead from the engine oil pressure switch after turning the main switch **OFF**.
2. Turn the main switch **ON** and connect a jumper lead from the lead to the chassis.
3. If the engine oil pressure indicator lamp does not light, the wiring harness is faulty.

(1) Engine Oil Pressure Switch

(a) From Oil Pressure Lamp

W1025954

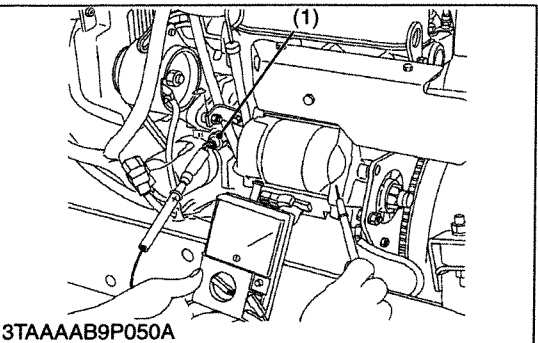
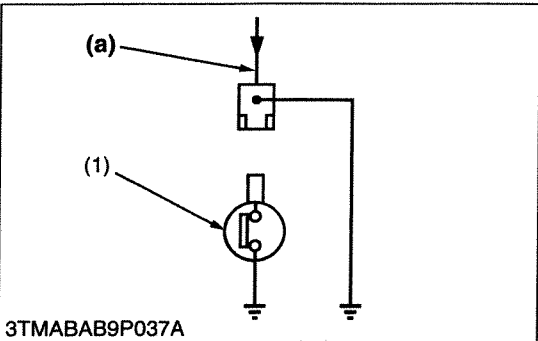

Engine Oil Pressure Switch Continuity

1. Measure the resistance with an ohmmeter across the switch terminal and the chassis.
2. If 0 ohm is not indicated in the normal state, the switch is faulty.
3. If infinity is not indicated at pressure over 4.9 kPa (0.5 kgf/cm², 7 psi), the switch is faulty.

Resistance (Switch terminal – Chassis)	In normal state	0 Ω
	At pressure over approx. 4.9 kPa (0.5 kgf/cm ² , 7 psi)	Infinity

(1) Engine Oil Pressure Switch

W1026084

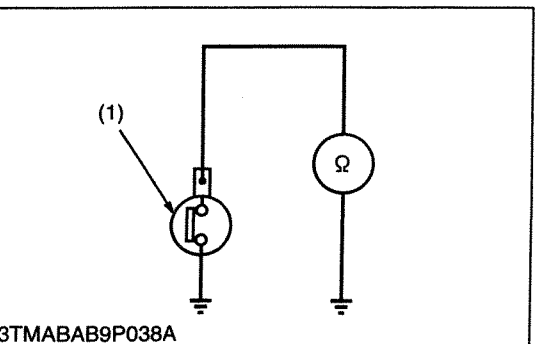

[5] GAUGES

(1) Checking

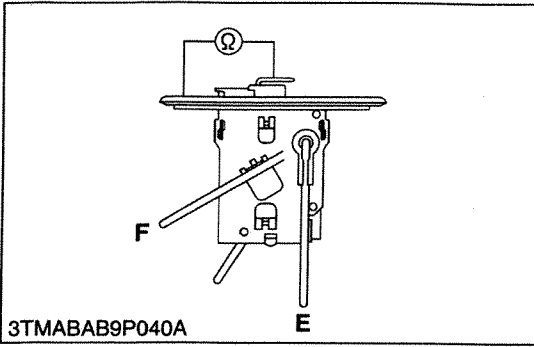

Fuel Level Sensor

1) Sensor Continuity

1. Remove the fuel level sensor from the fuel tank.
2. Measure the resistance with an ohmmeter across the sensor terminal and its body.
3. If the reference value are not indicated, the sensor is faulty.

Resistance (Sensor terminal – its body)	Reference value	Float at upper-most position	1 to 5 Ω
		Float at lower-most position	103 to 117 Ω

E : Empty

F : Full

W1024865

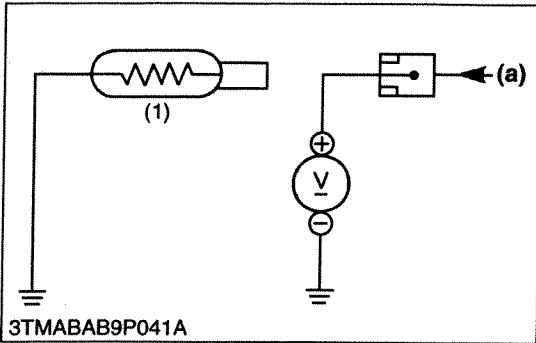

Coolant Temperature Sensor

1) Lead Terminal Voltage

1. Disconnect the lead from the coolant temperature sensor after turning the main switch off.
2. Turn the main switch on and measure the voltage with a voltmeter across the lead terminal and the chassis.
If the voltage differs from the battery voltage, the wiring harness, fuse or coolant temperature gauge is faulty.

Voltage	Lead terminal – Chassis	Approx. battery voltage
---------	-------------------------	-------------------------

2) Sensor Continuity

1. Measure the resistances with an ohmmeter across the sensor terminal and the chassis.
2. If the reference value is not indicated, the sensor is faulty.

Resistance (Sensor terminal – Chassis)	Reference value	Approx. 16.1 Ω at 120 °C (248 °F)
		Approx. 27.4 Ω at 100 °C (212 °F)
		Approx. 51.9 Ω at 80 °C (176 °F)
		Approx. 153.9 Ω at 50 °C (122 °F)

(1) Coolant Temperature Sensor

(a) From Temperature Gauge

W1025104

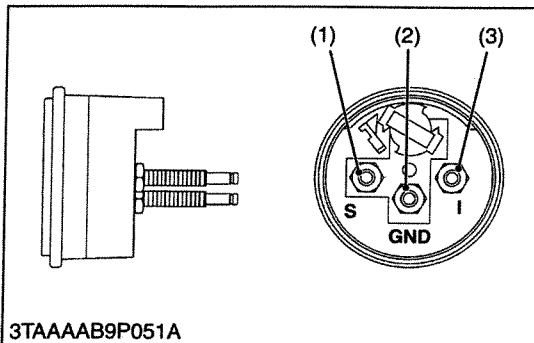
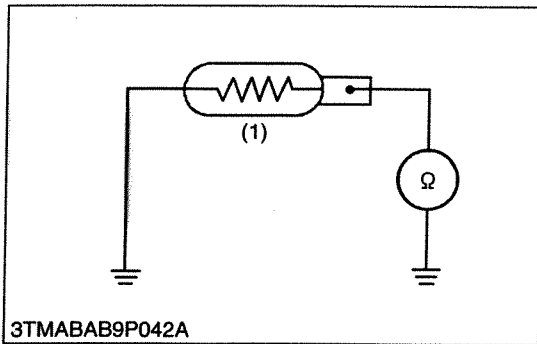

Fuel Gauge and Coolant Temperature Gauge Operation

1. Remove the under panel.
2. Turn the main switch to **ON** position. Measure the voltage with a voltmeter across the **I** terminal (3) and **GND** terminal (2) of the gauge.
3. If approx. battery voltage is indicated, the ignition and ground lead connections are good.
4. Turn the main switch to **OFF** position. Connect a jumper lead between **S** terminal (1) and **GND** terminal (2) of the gauge.
5. Turn the main switch to **ON** position. If the gauge resisters a full scale reading under those conditions, the gauge is good. If less than full scale reading is indicated, the gauge is defective and should be replaced.

(1) S Terminal

(3) I Terminal

(2) GND Terminal

W1027205