

# INDEX

INDEX TABLE	
S. NO	DIAGRAM
1	SH01 - INDEX
2	SH02 - GND
3	SH03 - FUSE AND RELAY BOX
4	SH04 - ECU
5	SH05 - CLUSTER METER
6	SH06 - CABIN
7	SH07 - INTERLOCK UNIT AND OTHER
8	SH08 - CRUISE OPTION

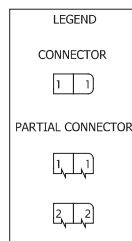

WIRE COLOR CODE	
CODE	COLOR
B	Black
R	Red
LG	Light Green
W	White
G	Green
BLU	Blue
Y	Yellow
O	Orange
BRN	Brown
R/G	Red/Green
Blu/B	Blue/Black
B/R	Black/Red
R/W	Red/White
Y/B	Yellow/Black
R/Blu	Red/Blue

HARNESS OVERVIEW	
TITLE	PN
HARNESS MAIN	7444864
HARNESS PANEL	7453008
HARNESS FUEL HEATER	7452996
HARNESS HEAD LAMP	7447646
HARNESS FENDER	7453009
HARNESS WIRE	7453010
HARNESS CABIN	7453011

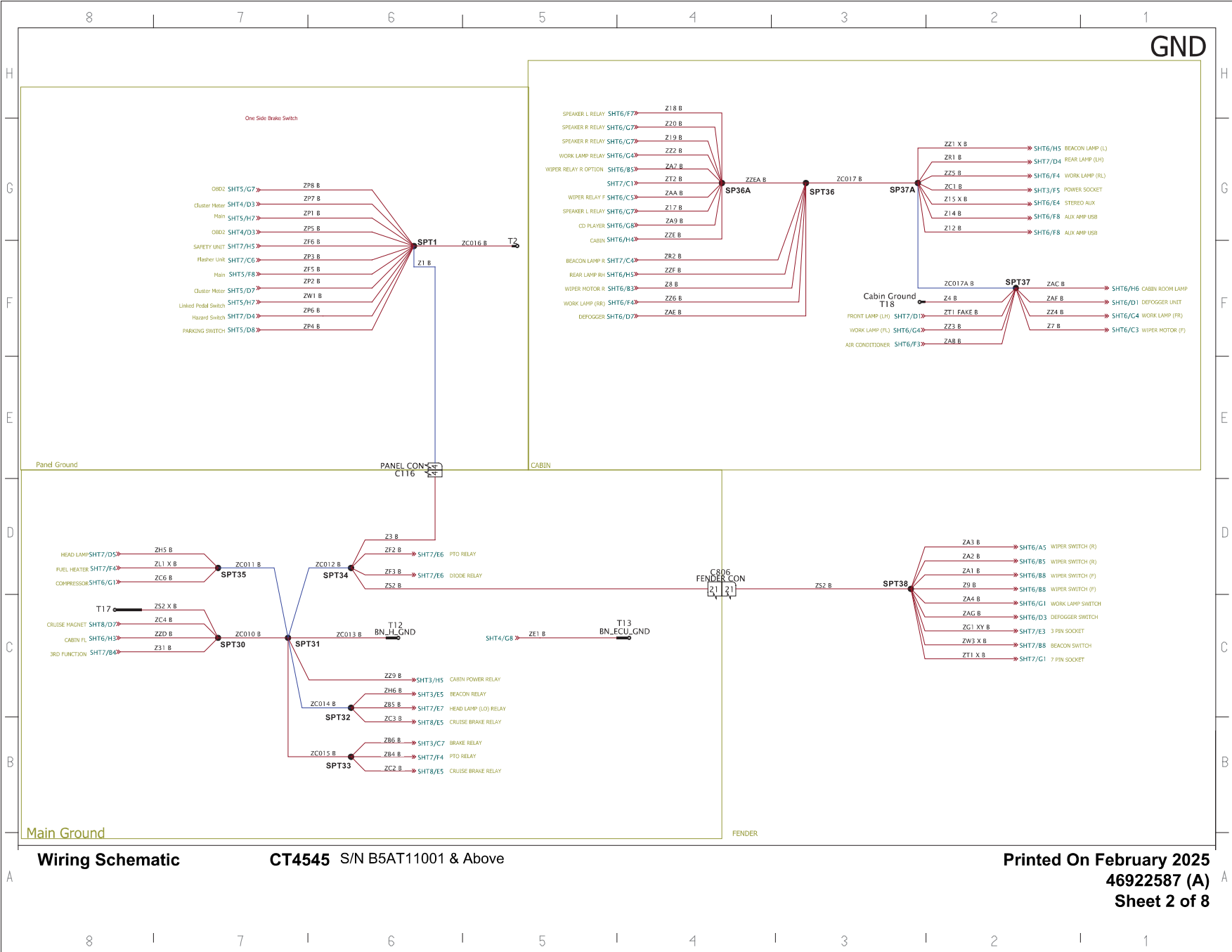

Wiring Schematic

CT4545 S/N B5AT11001 & Above

Printed On February 2025  
46922587 (A)  
Sheet 2 of 8

# FUSE AND RELAY BOX

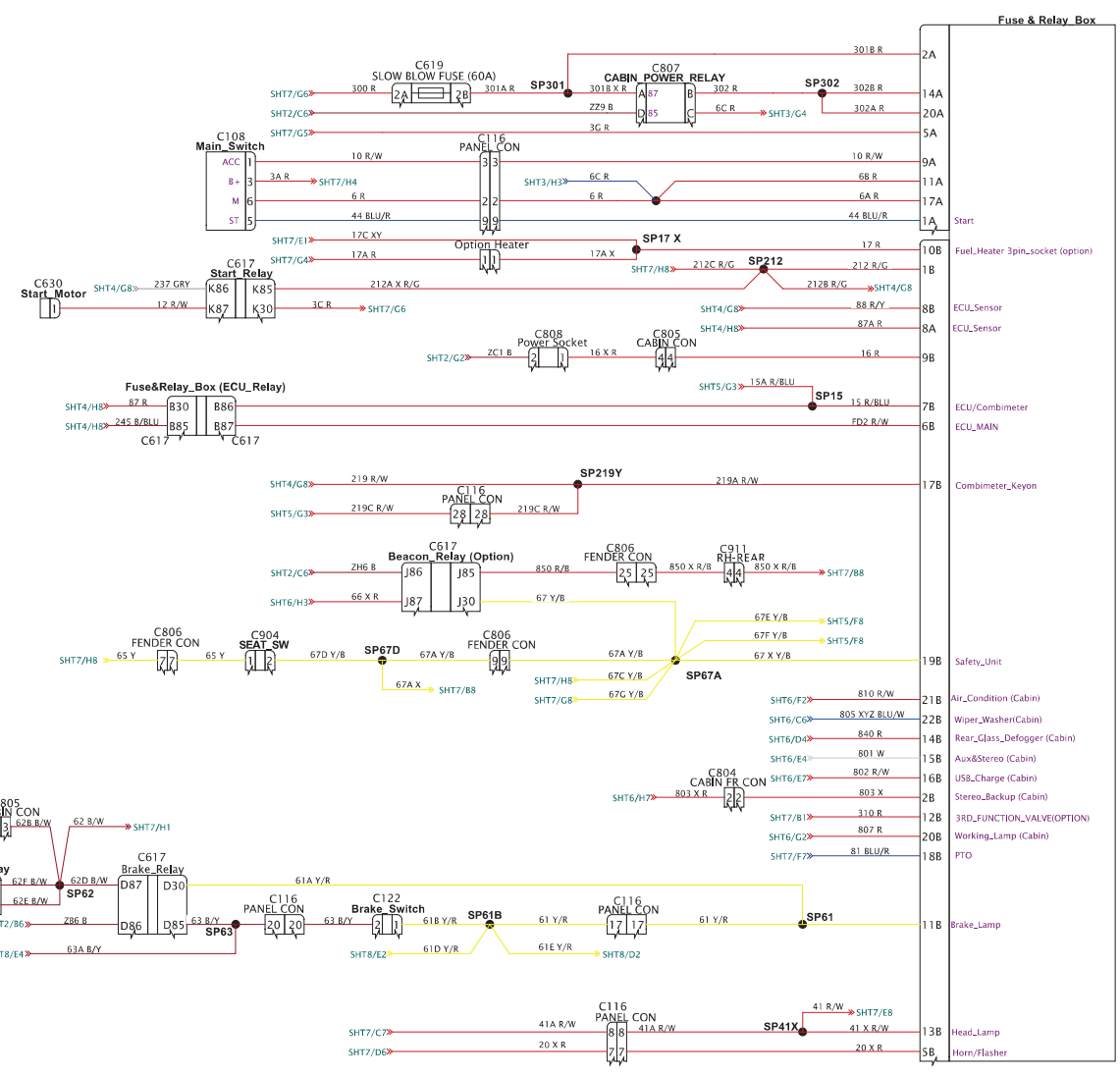

Wiring Schematic

CT4545 S/N B5AT11001 & Above

Printed On February 2025  
46922587 (A)  
Sheet 3 of 8

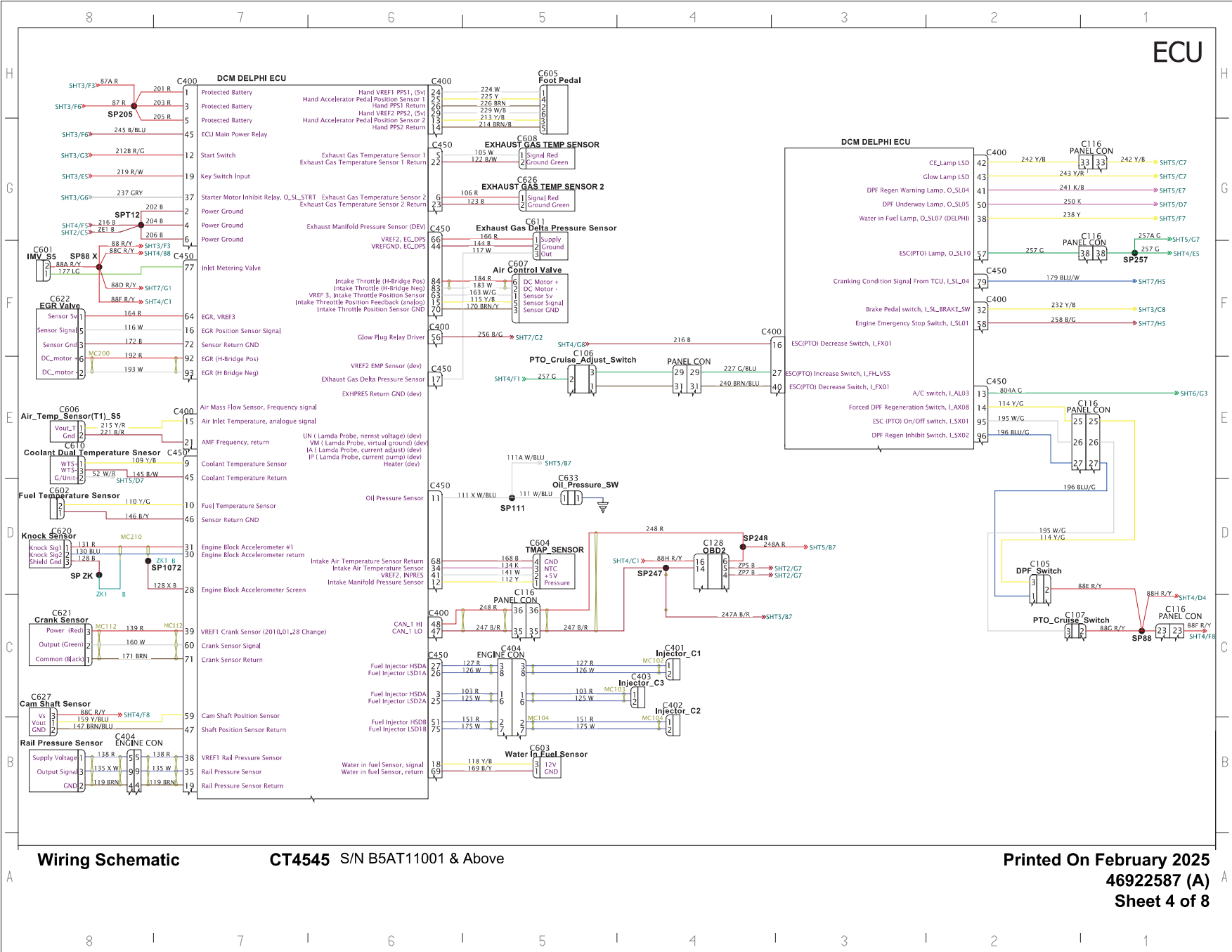

**ECU**

**Wiring Schematic**

**CT4545 S/N B5AT11001 & Above**

**Printed On February 2025  
46922587 (A)  
Sheet 4 of 8**



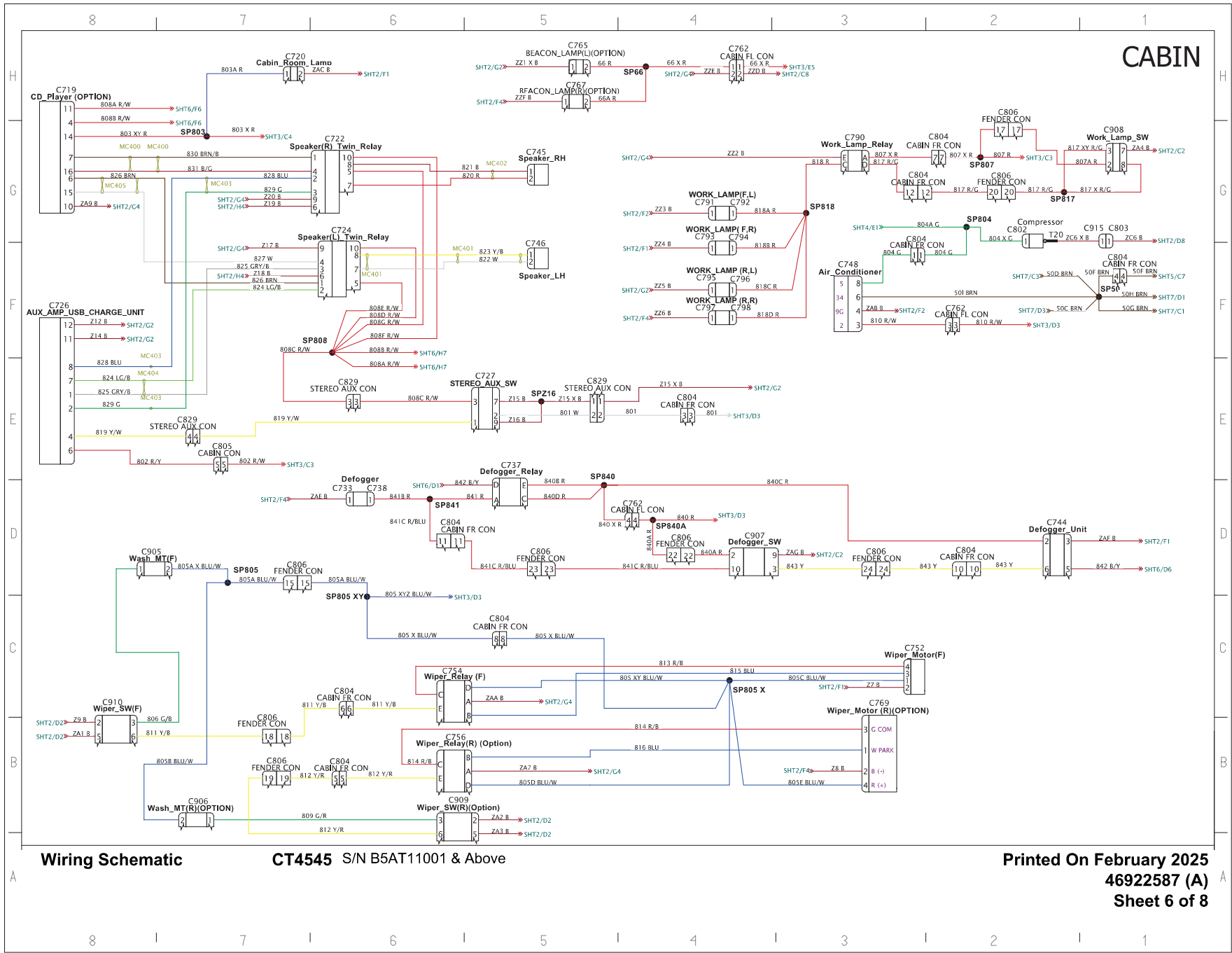

Wiring Schematic

CT4545 S/N B5AT11001 & Above



# CRUISE OPTION

