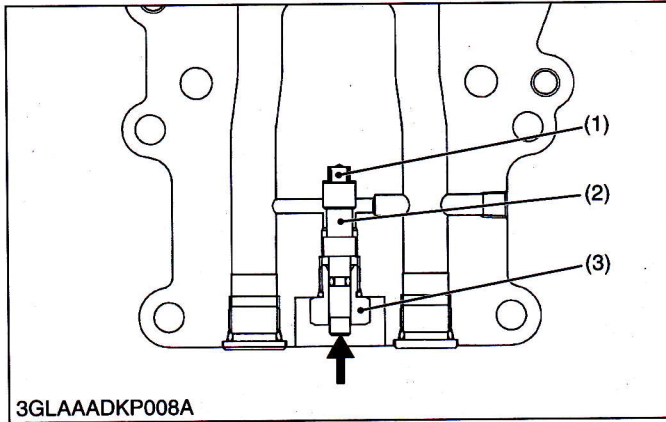

(4) By-pass Valve

Normally, when the engine is stopped, the pump shaft and pump cylinder block engaged with it do not rotate. Thus, the motor shaft does not rotate.

However, pressing the by-pass valve in the center section permits moving the machine with human power while the engine is stopped. The following paragraphs describe this mechanism:

Pressing the by-pass valve connects the forward and reverse loops in the center section. This allows oil to flow between the forward and reverse loops through the by-pass valve to rotate only the motor cylinder block.

This means that pressing the by-pass valve while the engine is stopped, that is, while the pump shaft is not rotating, permits rotating the motor shaft engaged with the motor cylinder block.

(1) By-pass Spring
(2) By-pass Spool

(3) By-pass Plug

W1014625